

CUSTOMER INFORMATION	
CUSTOMER NAME:	
PO NUMBER:	
JOB NUMBER:	374281
DATE PRINTED:	1/2/2025
PART NUMBER:	



ENGINE SPECIFICATION							
MOTOR:	Toyota	HEAD:	1FZ-FE	COMP RATIO:	9:1	ROD LENGTH:	6.063
MOTOR SIZE:	4.5	HEAD CC:	76	BLOCK HEIGHT:		TOP RING RADIAL:	.148
BORE:	3.940	INT VALVE DIA:		GASKET THK:	.048	2 nd RING RADIAL:	.164
STROKE:	3.740	EXT VALVE DIA:		DECK CLEARANCE:	.000	OIL RING RADIAL:	.121

PISTON SPECIFICATION							
FORGING#:	3913L	DISH/DEPTH:	-.059	PIN DIAMETER:	1.024		
DOME HEIGHT:	.000	CAM PROFILE:	CP34L	PIN FIT TO:	1.0250		
DOME/DISH VOL:	-7.970	TOP LAND VOL.:	-1.110	PISTON TO CYL CLEAR:	.0035	PIN LENGTH:	2.500

RING DATA	GROOVE WIDTH		GROOVE DIAMETER	
	INCH	METRIC	INCH	METRIC
TOP RING	.0400	1.016	3.5990	91.4146
2 ND RING	.0480	1.2192	3.5670	90.6018
OIL RING	.1110	2.8194	3.6380	92.4052

VALVE RELIEF	INTAKE		EXHAUST	
	INCH	METRIC	INCH	METRIC
POCKET DEPTH	-.1040	-2.6416	-.1040	-2.6416
POCKET ANGLE	9.000°		9.000°	
POCKET DIA.	1.8600	47.244	1.8600	47.244

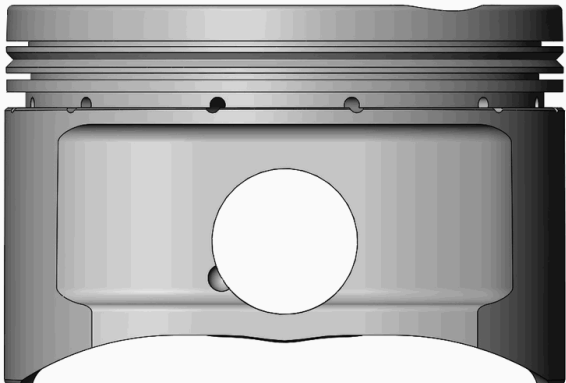

COATINGS:	-
-----------	---

PISTON WEIGHT:	494
----------------	-----

COMPRESSION HEIGHT:	1.656	CENTER OF PIN TO DECK
---------------------	-------	-----------------------

TURN DIA:	3.9365
-----------	--------

GAUGE POINT:	.500	INCHES UP FROM BOTTOM OF SKIRT
--------------	------	--------------------------------